

EDGE PULL - SONAR

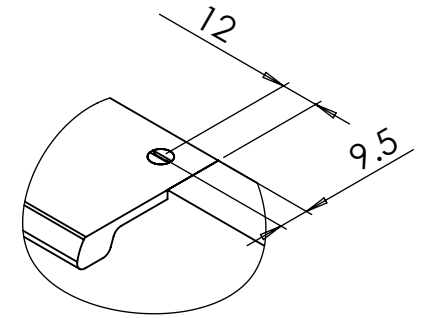

PULL LENGTH	DIMENSION 'A'	FIXINGS
50	50	2
100	100	2
150	150	2
200	200	3
300	300	3
500	500	4

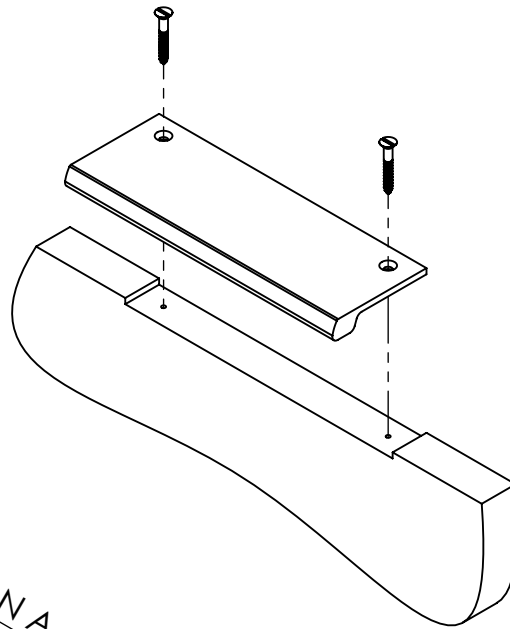
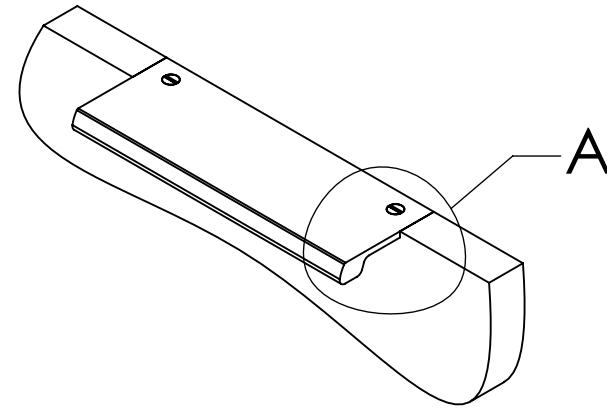

DETAIL A

FIXING HOLE CENTER - 9.5MM FROM REAR EDGE OF PULL, 12.0MM FROM EDGE

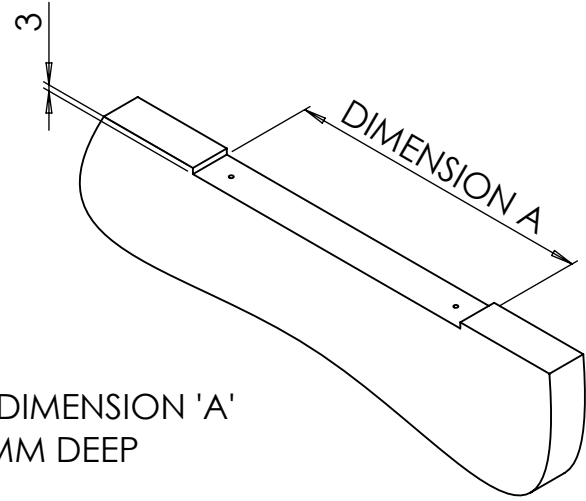

REBATE DIMENSION 'A'
3MM DEEP

TURNSTYLE DESIGNS – CARE OF MATERIALS AND FINISHES



BRASS – PLATED FINISHES

Bright Chrome (BC) - INT/EXT / Matt Black Chrome (CB) - INT/EXT / Polished Nickel (PN) - INT / Satin Nickel (SN) - INT

Wipe clean with a soft, damp cloth and dry with a clean, soft cloth.

BRASS – LIVING FINISHES

Burnished Brass (BH) - INT/EXT / Burnished Nickel (NH) - INT / Fine Antique Brass (FA) - INT/EXT / Polished Brass (PU) - INT/EXT / Satin Brass (TW) - INT

Vintage Nickel (VN) - INT / Vintage Patina (VP) - INT/EXT

Living finishes will develop their own individual patina over time as they react with their environment. Once installed a number of factors such as handling, age and environment will lead to gradual wear and oxidation, resulting in each piece developing a unique character and elegance. This is a natural process and is a feature, not a fault, of the base material or finishing technique.

Living finishes are supplied with a protective wax coating to protect the product during transit and installation. These finishes should be cleaned with a soft, lint free cloth, a good quality wax can be reapplied if desired. Polished Brass (PU) can be cleaned with a brass metal polish should you wish to maintain its shiny appearance.

LEATHER

Black (BL) - INT / Bridle White (BW) - INT / Chestnut (CN) - INT / Chocolate (CT) - INT / Slate Grey (GC) - INT / Tan (TA) - INT

Leather is a natural material that will age over time and with use, developing a unique patina; this is part of its character and should be expected. Wipe leather surfaces clean with a soft, damp cloth using heavily diluted soapy water (1 part soap to 12 parts water) then dry with a clean, soft cloth. Once dry, the leather can be fed with a quality beeswax or neutral leather cream.

Marks and dents within the leather can be 'worked out' using a boning tool. Work the marked area in a gentle circular motion to bring the fibres and natural oils back to the surface.

AMALFINE™

Alupewt (AP) - INT / Black Bronze (BB) - INT / Bone (BN) - INT / Cocoa (CO) - INT / Sand (SA) - INT / Silver Bronze (SB) - INT

Wipe clean with a soft, damp cloth or soft brush using heavily diluted warm soapy water then dry with a clean, soft cloth. Once dry the Amalfine™ can be finished with a good quality beeswax.

Do not attempt to clean any finishes with abrasive or solvent based solutions.

INT – Suitable for Interior Applications
EXT - Suitable for Exterior Applications